

INSTANDSETZUNGSHINWEISE
REPAIR INSTRUCTIONS
INSTRUCTIONS DE REPARATION
INSTRUCCIONES DE REPARACION



Bohrhammer
Rotary Hammer
Marteau perforateur
Martillo perforador

Typ 3 611 J00 R00 = GBH 36 V-LI

Änderungen vorbehalten. Unsere Erzeugnisse werden stets dem neuesten technischen Stand angepaßt. Deshalb behalten wir uns Änderungen vor.

Modifications. Our products are constantly modified to meet new technical standards. We therefore reserve the right to alter data and specifications without prior notice.

Modifications. Nos produits sont continuellement adaptés aux dernières nouveautés techniques et les dates sont données sous réserve de changement.

Modificaciones. Nuestros fabricados van siendo adaptos constantemente a las últimas conquistas técnicas. Por ello, tenemos que reservarnos el derecho de introducir modificaciones en los datos técnicos.

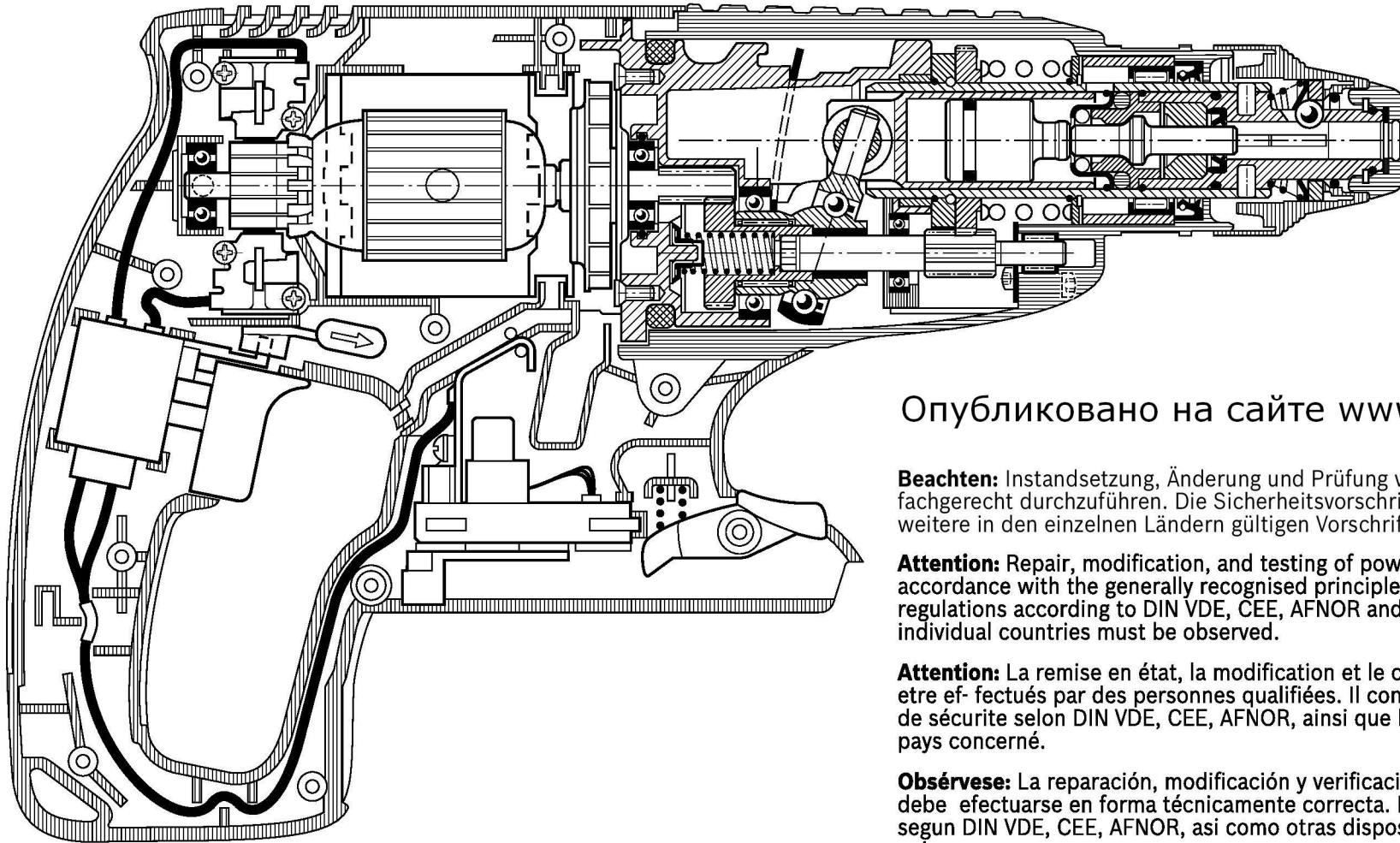

Опубликовано на сайте www.rem-5.ru

Beachten: Instandsetzung, Änderung und Prüfung von Elektrowerkzeugen sind fachgerecht durchzuführen. Die Sicherheitsvorschriften nach DIN VDE, CEE, AFNOR und weitere in den einzelnen Ländern gültigen Vorschriften sind einzuhalten.

Attention: Repair, modification, and testing of power tools must be carried out in accordance with the generally recognised principles of engineering practise. Safety regulations according to DIN VDE, CEE, AFNOR and further regulations applicable in individual countries must be observed.

Attention: La remise en état, la modification et le controle des outils électriques doivent être effectués par des personnes qualifiées. Il convient de respecter les prescriptions de sécurité selon DIN VDE, CEE, AFNOR, ainsi que les réglementations en vigueur dans le pays concerné.

Obsérvese: La reparación, modificación y verificación de herramientas electricas mano debe efectuarse en forma técnicamente correcta. Respetar las normas de seguridad segun DIN VDE, CEE, AFNOR, asi como otras disposiciones vigentes en los distintos países.

Zerlegen

Für die Demontage werden handelsübliche Werkzeuge benötigt.

1. Eingangsprüfung durchführen.
Beachten:
Die Sicherheitsvorschriften nach DIN, VDE, CEE, AFNOR und weitere in den einzelnen Ländern gültigen Vorschriften sind einzuhalten.

Disassembly

Use normal trade tools by disassembly.

1. Carry out power supply check.
Attention:
Safety regulations according to DIN, VDE, CEE, AFNOR and further regulations applicable in individual countries must be observed.

Démontage

Pour le démontage, des outils en usage dans le commerce sont nécessaires.

1. Effectuer un contrôle préliminaire.
Attention:
Respecter les instructions de sécurité selon DIN, VDE, CEE, AFNOR et les autres instructions valables dans les pays respectifs.

Desmontaje

Para el desmontaje no se precisan herramientas especiales.

1. Realizar control de recepción.
Atención:
Atenerse a las prescripciones de seguridad según DIN, VDE, CEE, AFNOR y a las prescripciones adicionales específicas que pudieran existir en los respectivos países.

1.

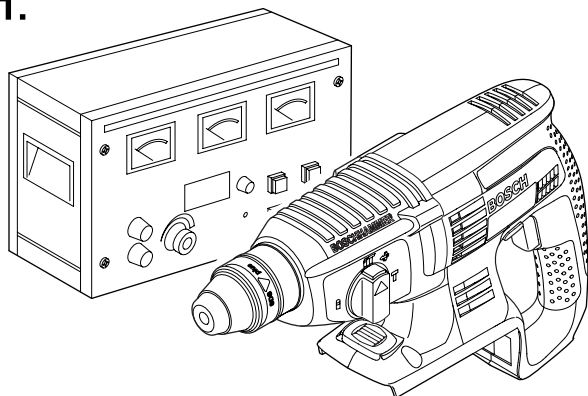

2.

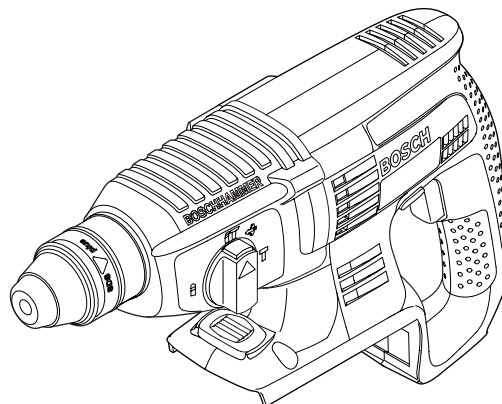

2. Zerlegen nach Explosions-, Schnittzeichnung und diesem Instandsetzungshinweis.
2. Disassembly using explosion, cut-away drawings and these repair instructions!
2. Démontez l'appareil suivant la vue éclatée, le plan en coupe et ces instructions de réparation.
2. Realizar el desmontaje conforme a los dibujos en perspectiva y en sección, y a estas instrucciones de reparación.

3.

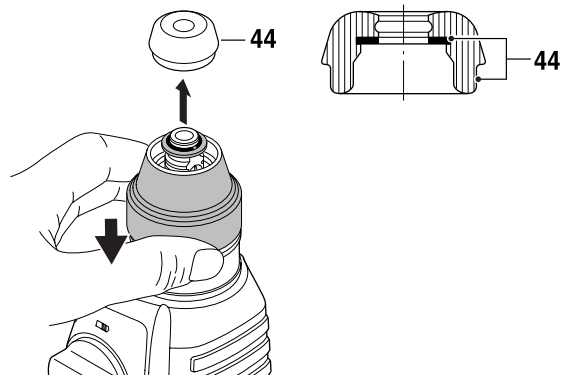

3.1

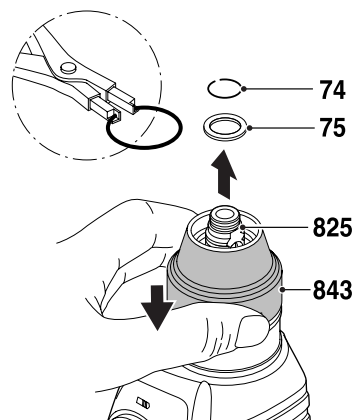

3.2

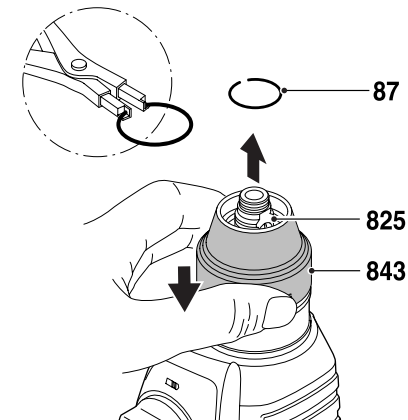

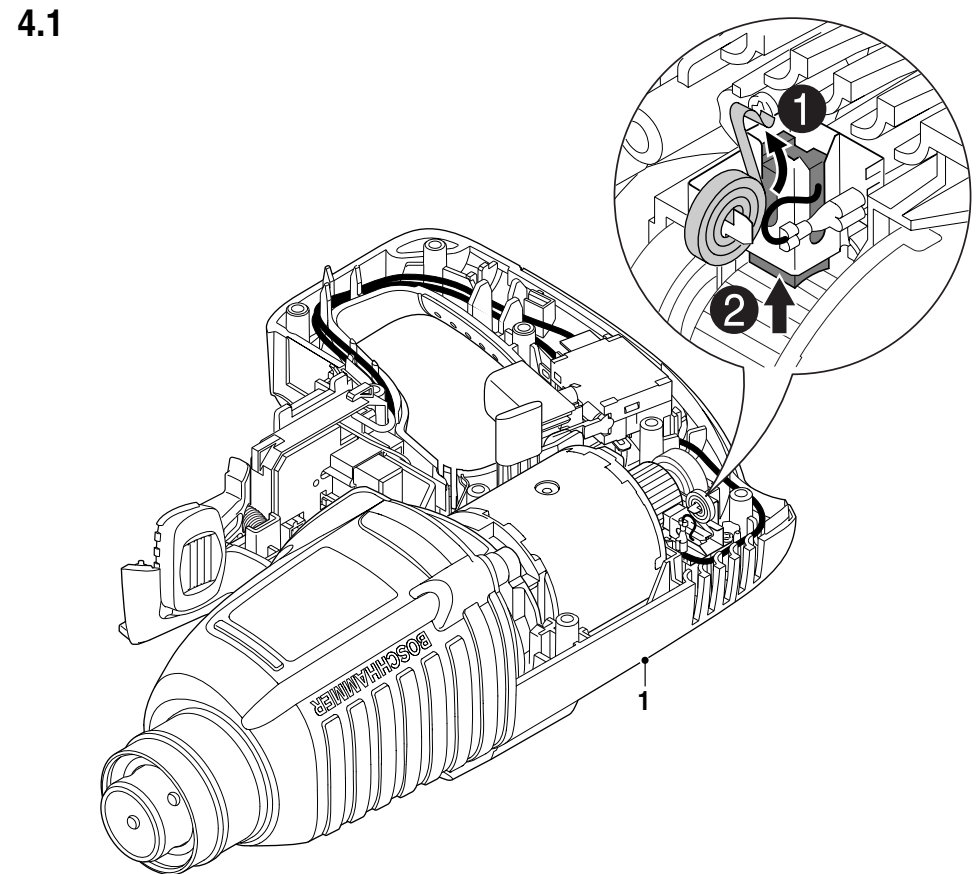
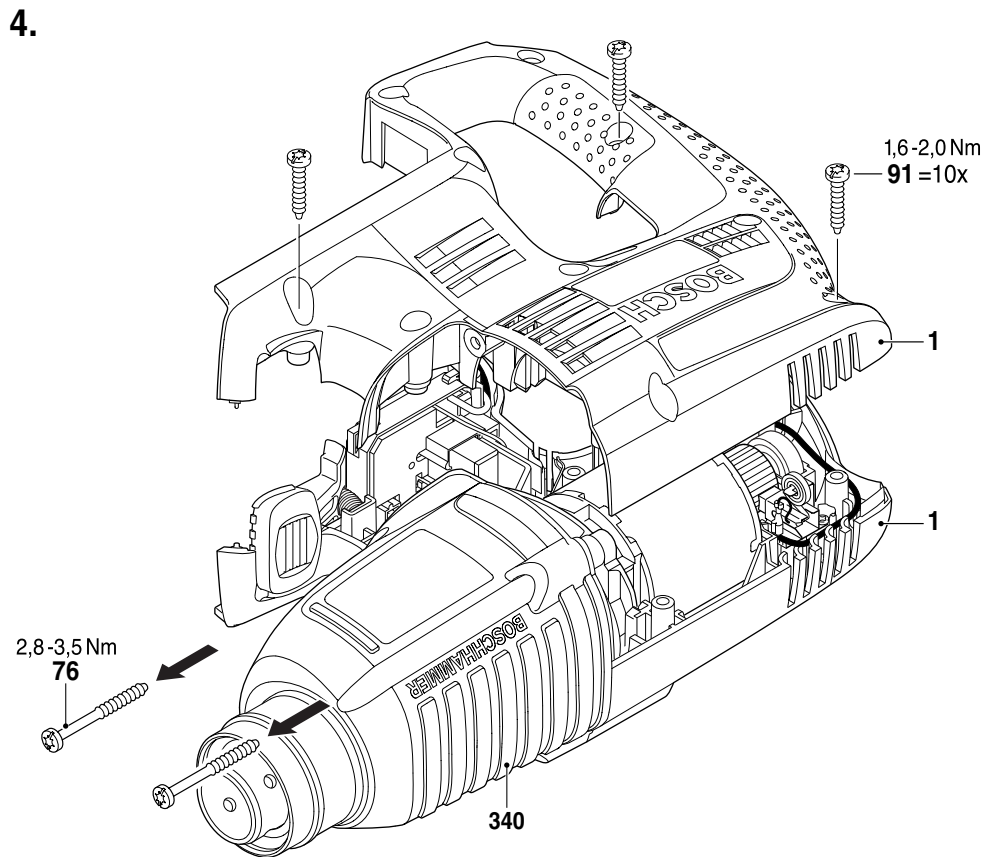
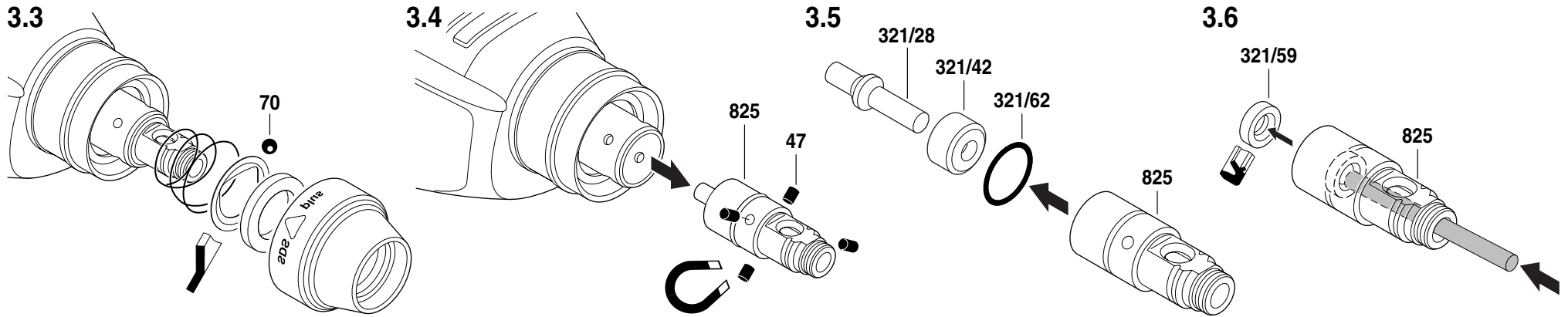

4.2

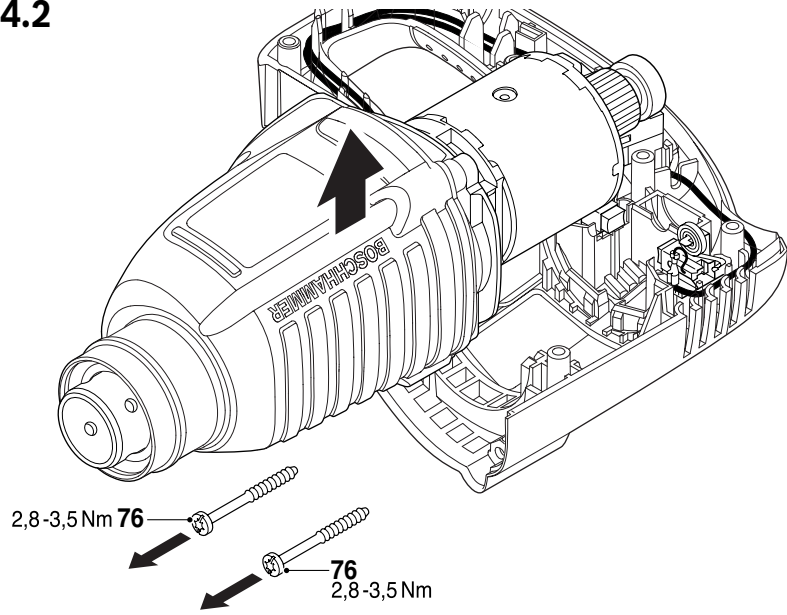

4.3

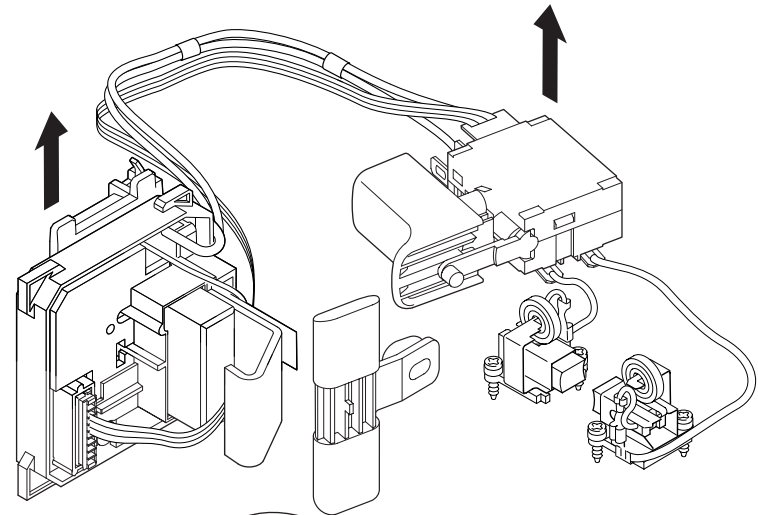

4.4

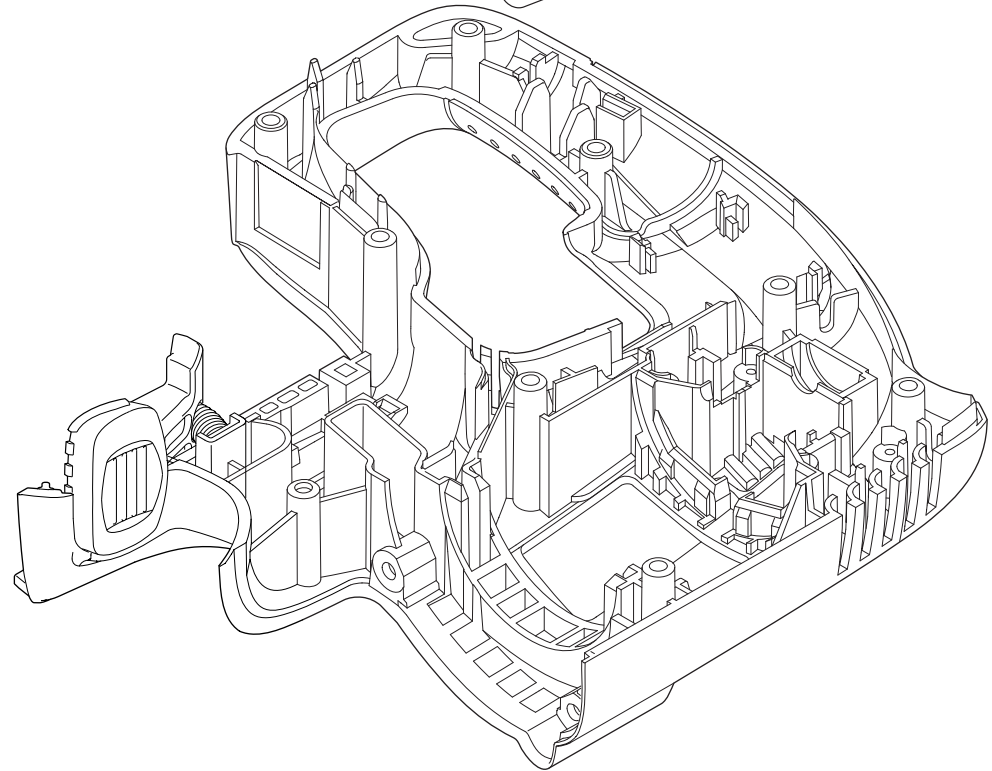
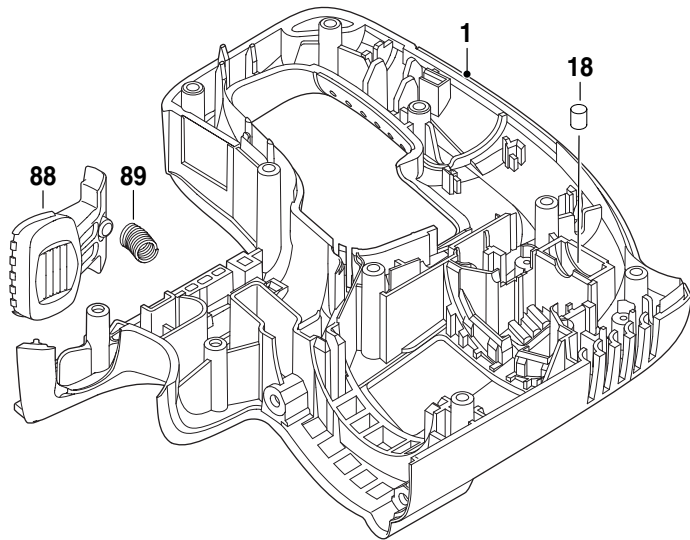

4.4

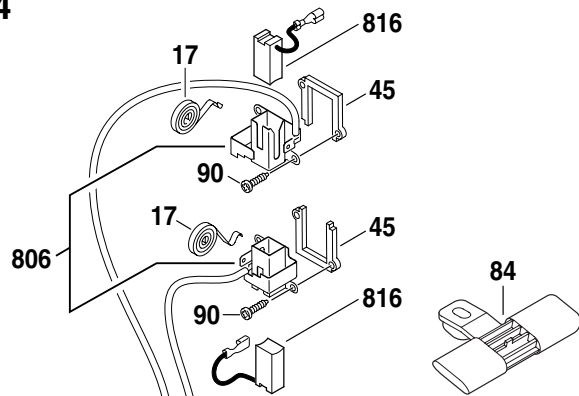

5.

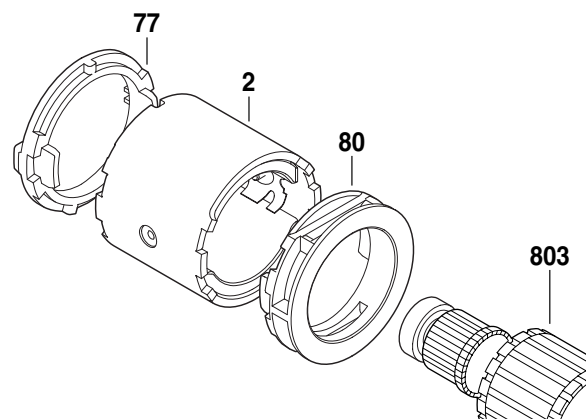

5.1

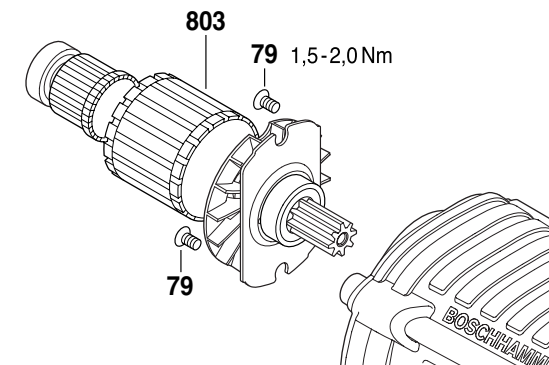

5.2

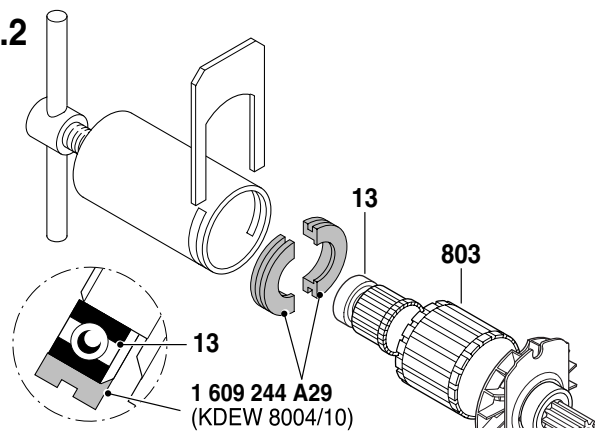

6.

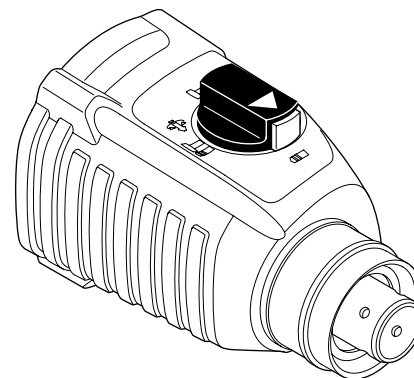

6.1

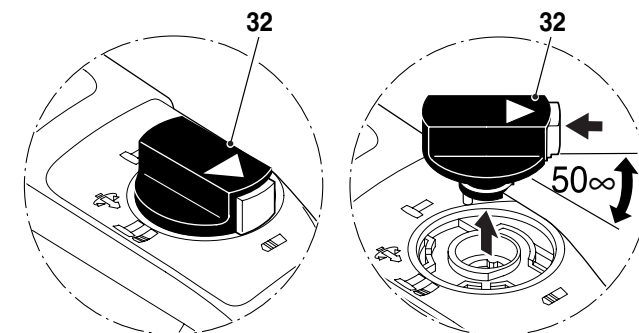

6.2

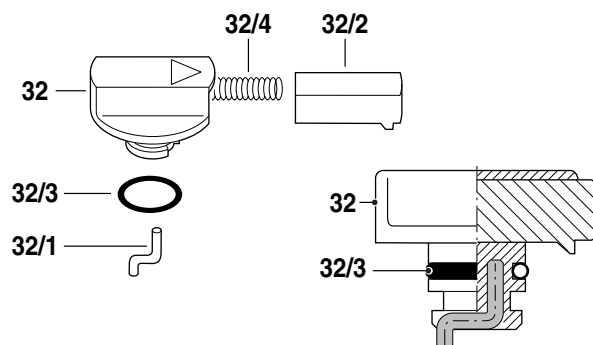

7.

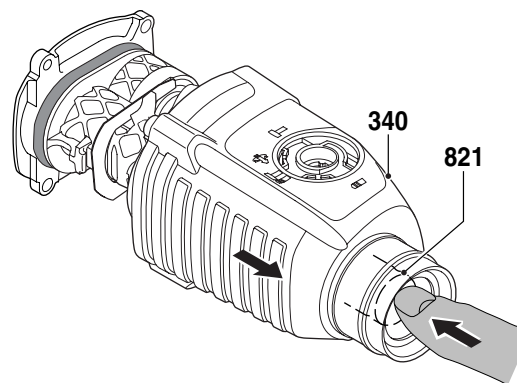

7.1

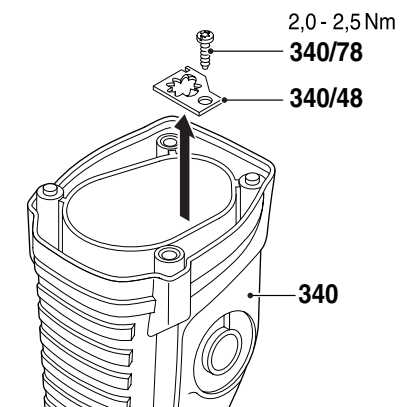

7.2

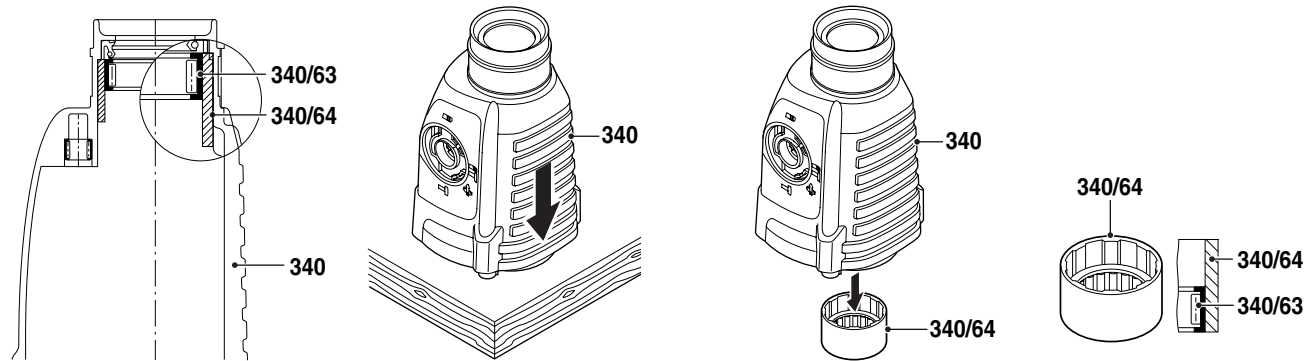

7.3

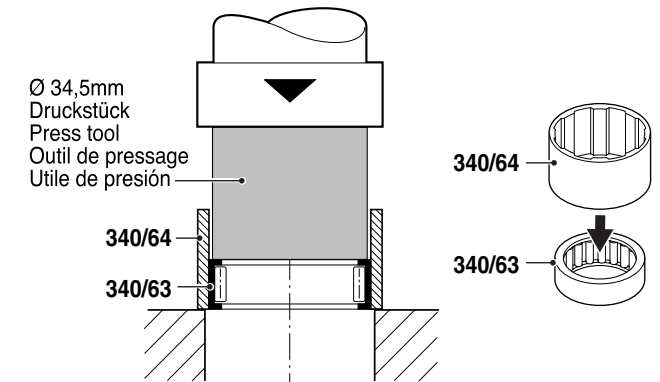

7.4

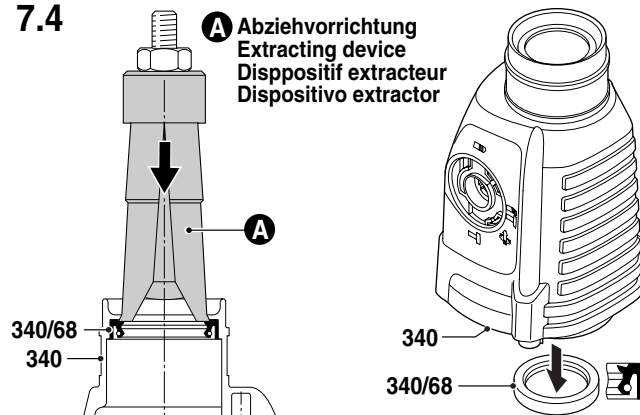

8.

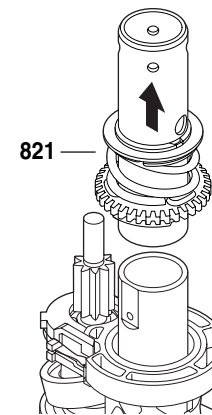

8.1

Ausrastmoment der Sicherheitskupplung prüfen
Check release torque of safety clutch.
Controler le moment de désaccouplement
de l' accouplement de sécurité.
Comprobar el par de desenchava-
miento del embrague de seguridad

Ausrastmoment 20 - 28Nm
Slipping point of clutch
Couple de glessement
Momento de desenchavamiento

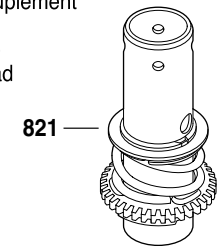

Bei 17 Nm und weniger - Kupplung ersetzen!
By 17 Nm and less - replace slipping clutch!

8.2

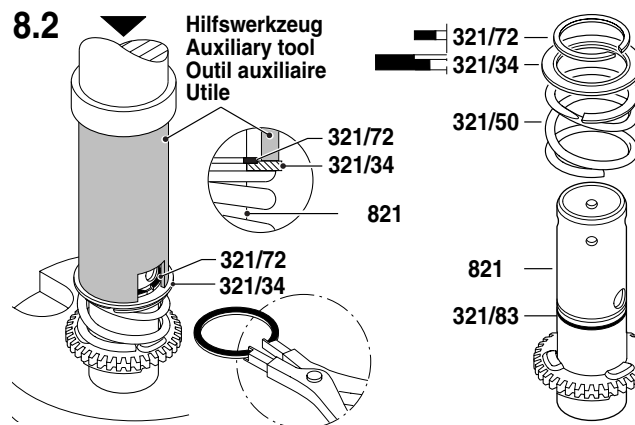

8.3

Hilfswerkzeug zum Selbstanfertigen
Auxiliary tool (for your own manufacture)
Outil auxiliaire (fabrication locale)
Utile (fabricaci n particular)

H lse
Sleeve
Douille
Manguito

8.4

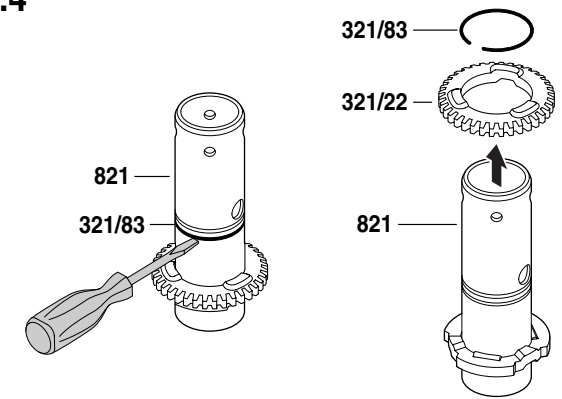

8.5

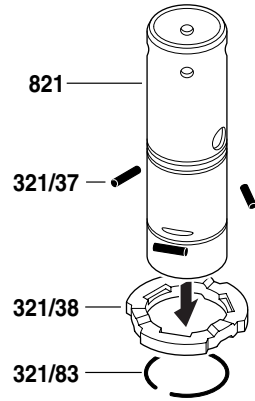

8.6

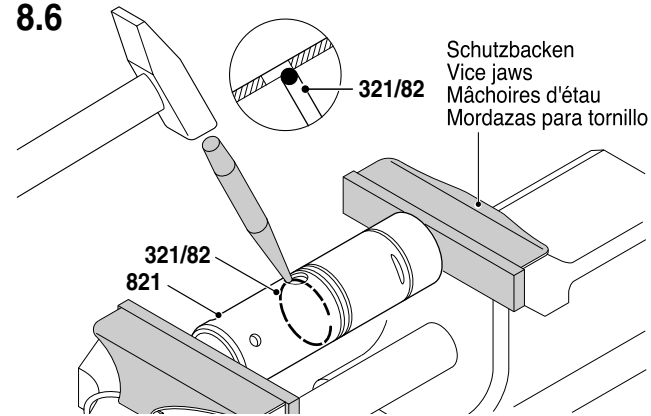

8.7

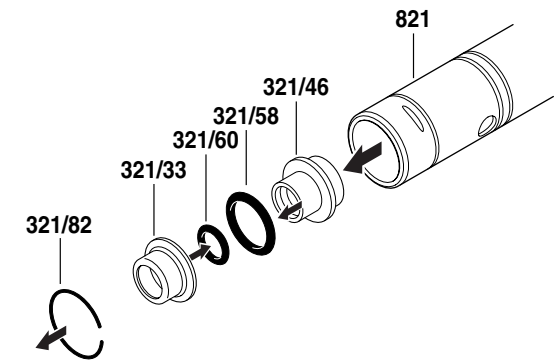

9.

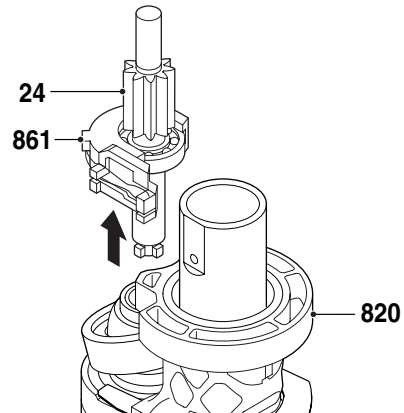

9.1

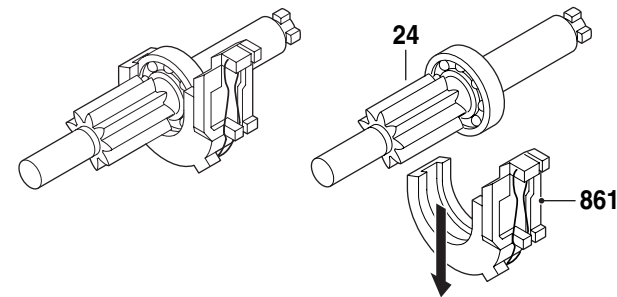

9.2

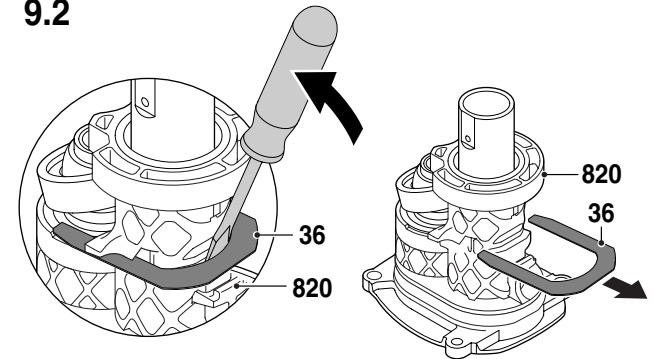

9.3

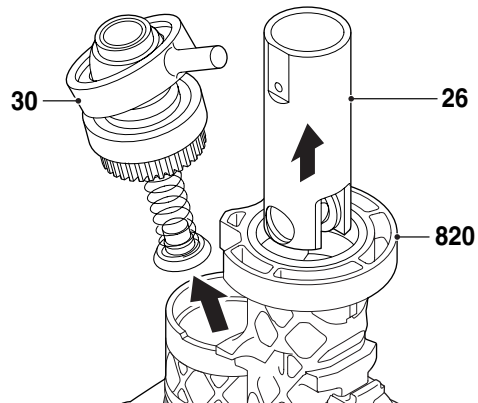

9.4

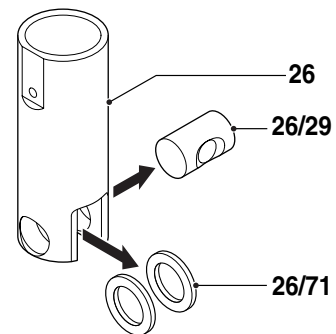

9.5

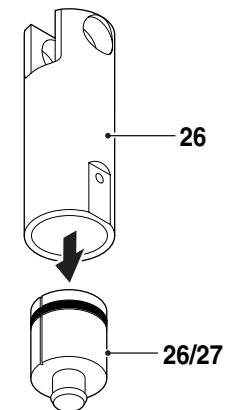

9.6

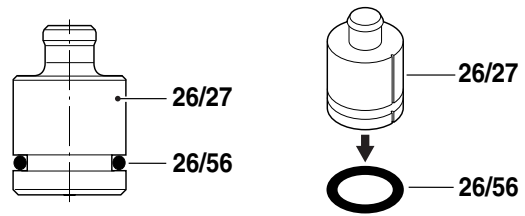

9.7

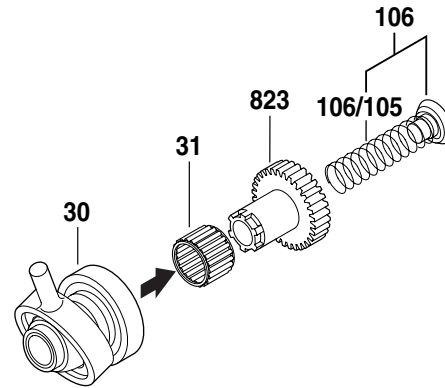

9.8

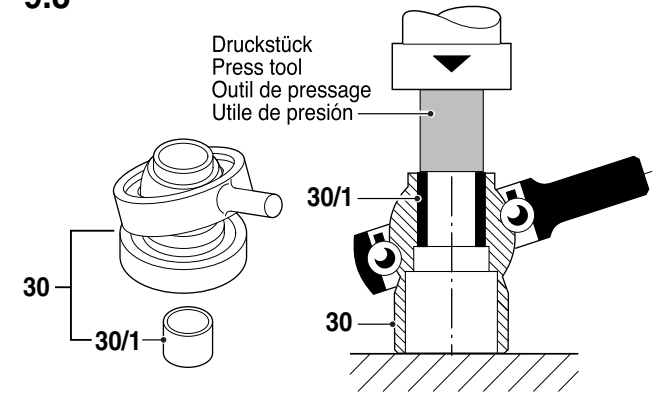

10.

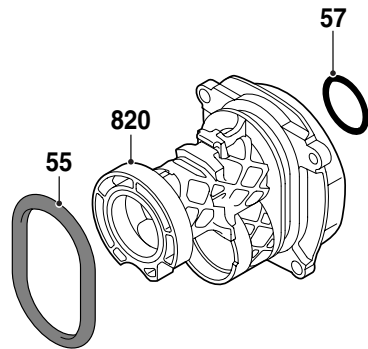

10.1

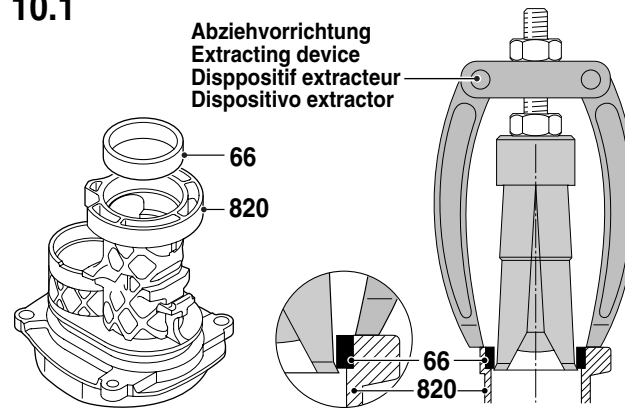

Zusammenbau

Montage nach Explosionszeichnung und diesem Instandsetzungshinweis.

Alle Teile sind gereinigt, abgenutzte und beschädigte Teile werden ersetzt.

Nur Original-Ersatzteile verwenden.

Zähne aller Zahnräder mit Fett 1 615 430 001 bestreichen.

Bitte Schmierhinweise beachten!

Assembly

Assembly using explosion drawings and these repair instructions!

Clean all parts, replace worn-out and damaged parts.

Use only original spare parts!

Grease all gear teeth 1 615 430 001.

Please note lubrication instructions!

Montage

Le montage s'effectue selon la vue éclatée et les instructions de réparation suivantes.

Toutes les pièces sont nettoyées, les pièces usées ou endommagées doivent être remplacées par des nouvelles. Pour le remplacement de pièces, n'utiliser que des pièces d'origine.

Les dents graisser 1 615 430 001.

Respecter les instructions de graissage!

Montaje

Realizar el montaje conforme a los dibujos en perspectiva y a estas instrucciones de reparación.

Todas las piezas deben estar limpias. Las piezas desgastadas o dañadas deben reemplazarse por piezas nuevas. Utilizar solamente piezas de repuesto originales.

Dientes engrasar 1 615 430 001.

Observar las instrucciones de lubricación!

21.

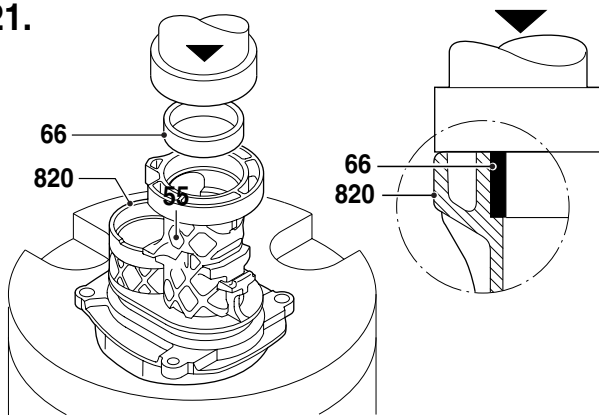

21.1

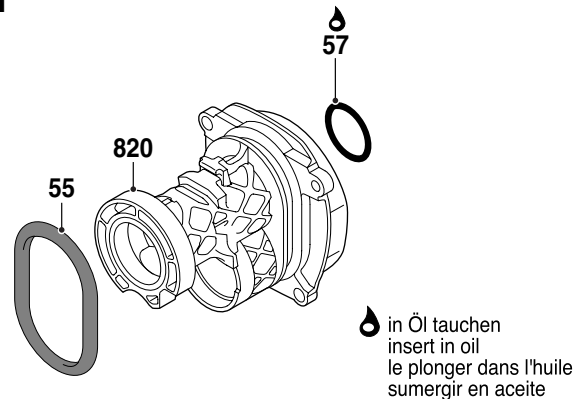

22.

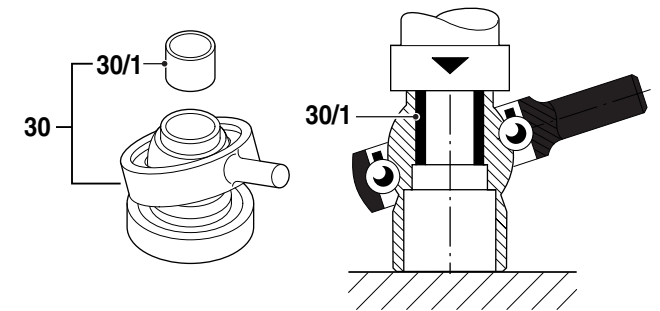

22.1

Gleitflächen einstreichen
Lubricate sliding surfaces
Enduire les parties mouvantes
engrasar las piezas móviles

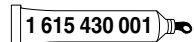

fetten / graissees
grease / engrasar

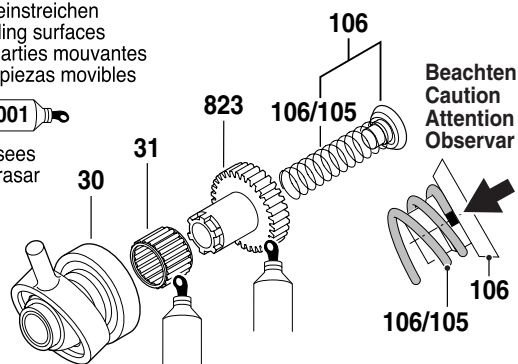

22.2

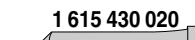
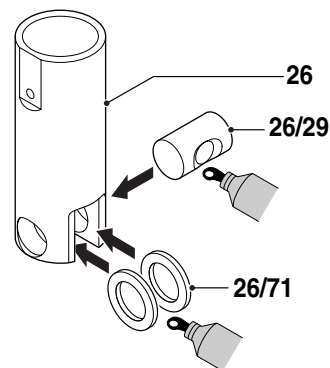

Gleitflächen einstreichen
Lubricate sliding surfaces
Enduire les parties mouvantes
engrasar las piezas móviles

22.3

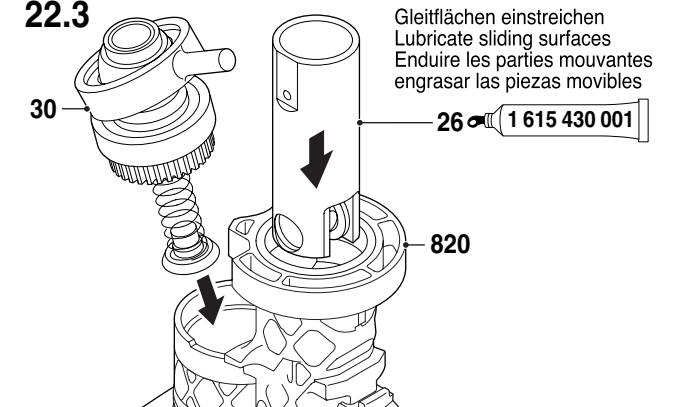

22.4

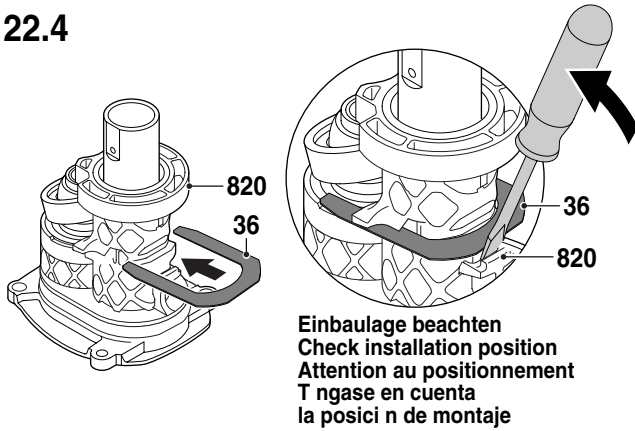

22.5

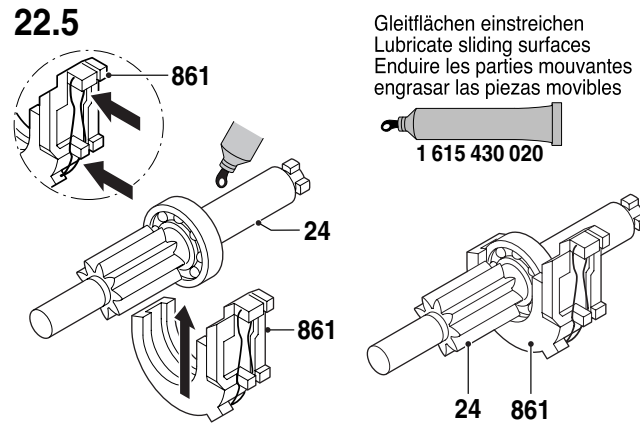

22.6

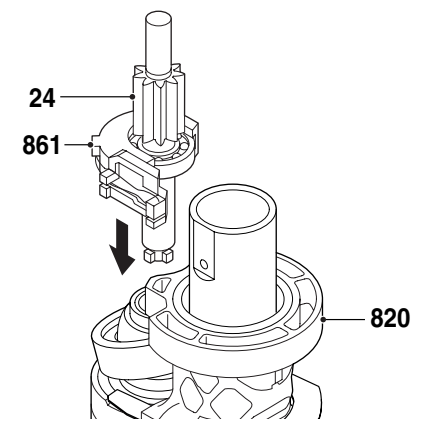

22.7

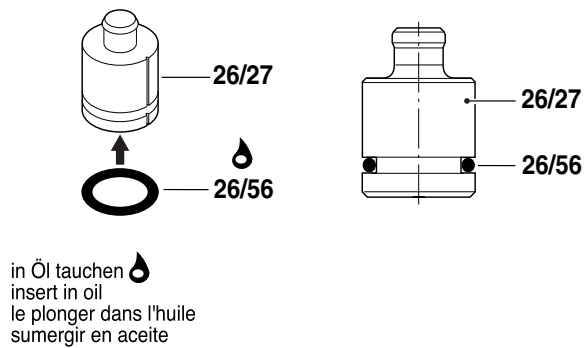

22.8

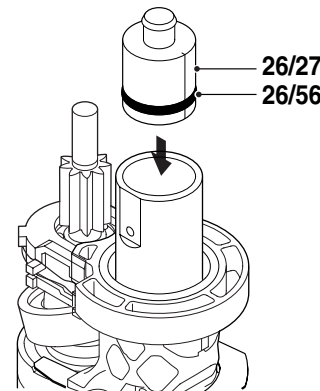

23.

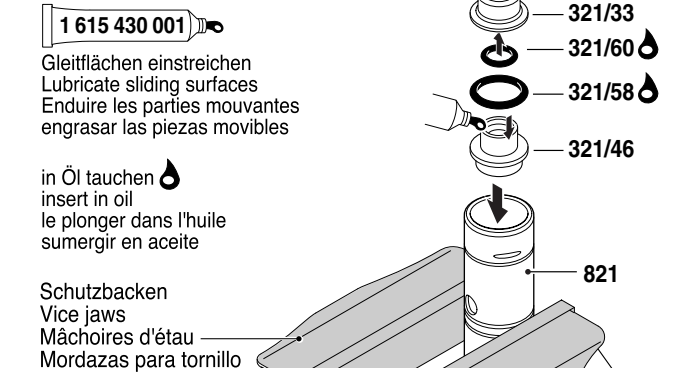

23.1

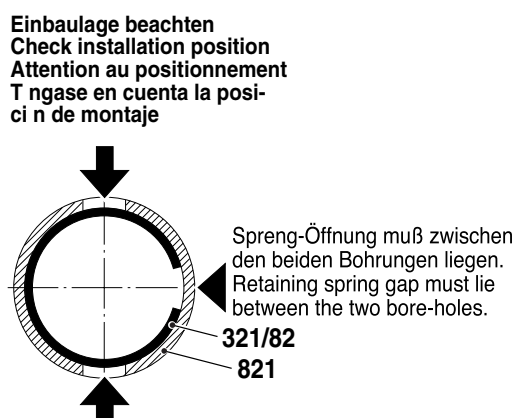

23.2

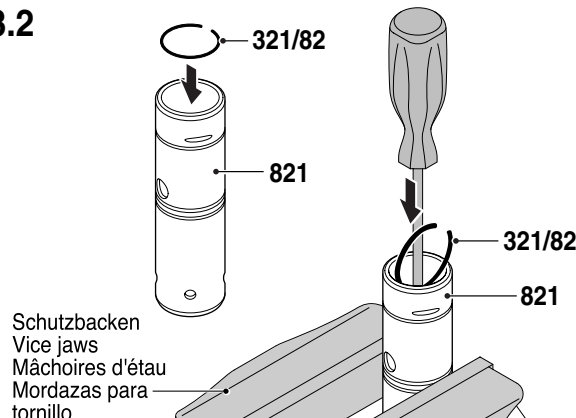

23.3

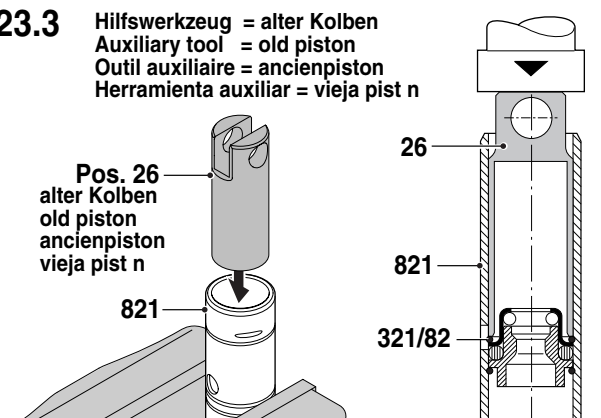

23.4

mit Fett fixieren
attach with grease
lubrifier
lubricar con grasa

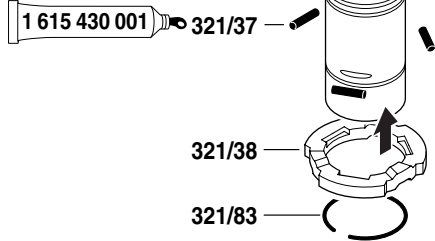

23.5

Zähne fetten
grease teeth
dents graissées
engrasar los dientes

Gleitflächen einstreichen
Lubricate sliding surfaces
Enduire les parties mouvantes
engrasar las piezas móviles

innen fetten
grease inside surface

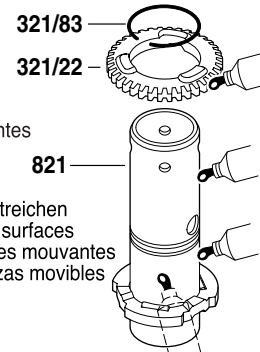

23.6

Einbaulage beachten
Check installation position
Attention au positionnement
T ngase en cuenta la posici n
de montaje

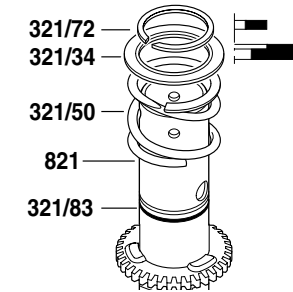

23.7

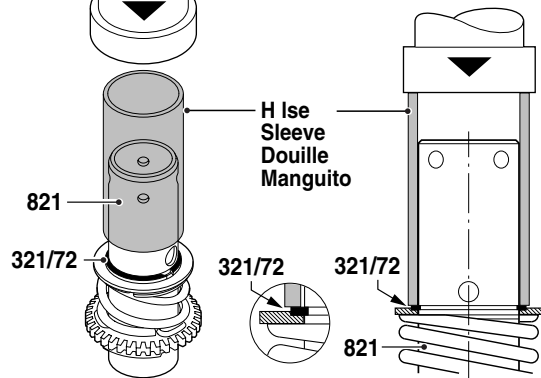

23.8

Ausrastrmoment der Sicherheitskupplung prüfen
Check release torque of safety clutch.
Controler le moment de désaccouplement
de l' accouplement de sécurité.
Comprobar el par de desenchlavo-
miento del embrague de seguridad

Ausrastrmoment 20 - 28Nm
Slipping point of clutch
Couple de glessement
Momento de desenchlavamiento

Bei ? Nm und weniger - Kupplung ersetzen!
By ? Nm and less - replace slipping clutch!

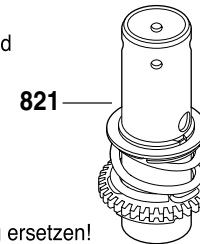

23.9

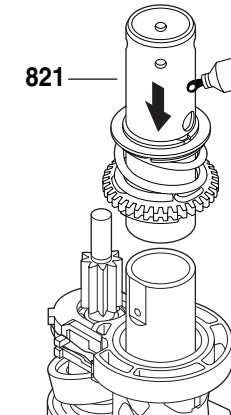

24.

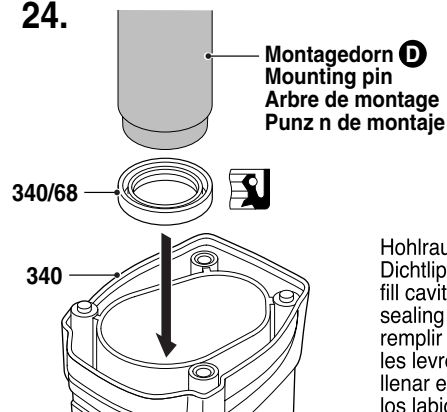

Hohlraum zwischen
Dichtlippen füllen
fill cavity between
sealing lips
remplir cavite entre
les levres du joint
llenar el vacio entre
los labios del reten

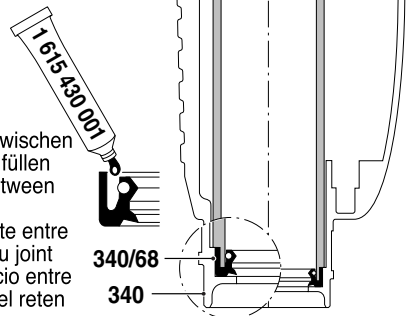

Hilfswerkzeug zum Selbst-
anfertigen / Auxiliary tool
(for your own manufacture)
Outil auxiliaire
(fabrication locale)
Utile (fabricaci n particular)

Montagedorn M
Mounting pin
Arbre de montage
Punz n de montaje

Maße in mm
Dimensions in mm
Cotes en mm
Medidas en mm

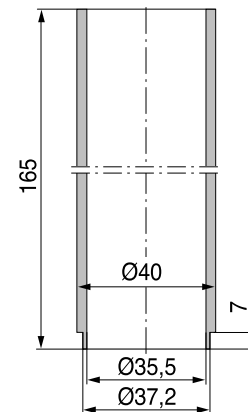

24.1

wird gefettet geliefert
pre greased delivered
pré graissé livré
pre engrasado ent regado

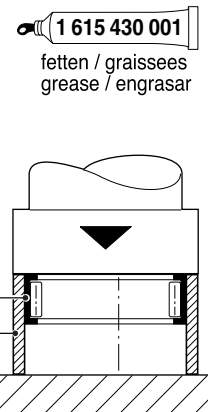

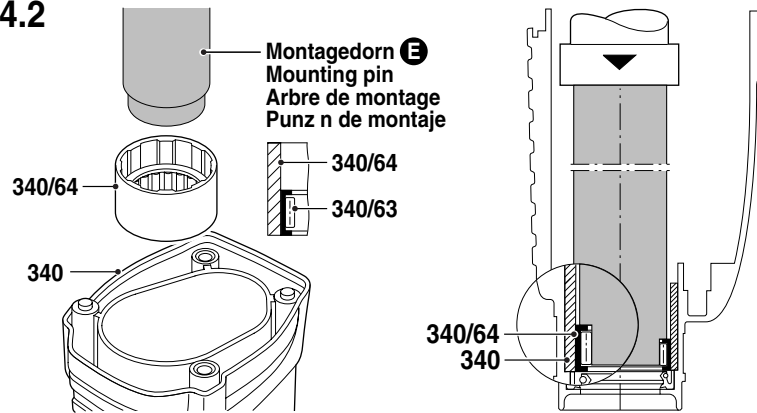
24.2

Hilfswerkzeug zum Selbst-
anfertigen / Auxiliary tool
(for your own manufacture)
Outil auxiliaire
(fabrication locale)
Utile (fabricaci n particular)

Montagedorn **E**
Mounting pin
Arbre de montage
Punz n de montaje

Maße in mm
Dimensions in mm
Cotes en mm
Medidas en mm

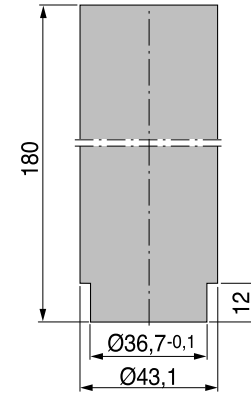
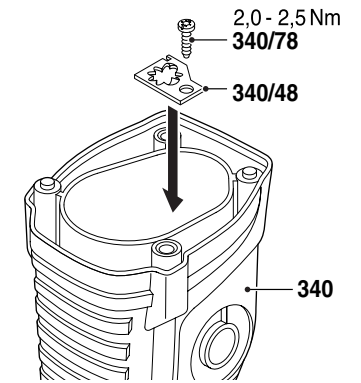
**24.3**

24.4 Teile fetten (35 g); Rest in Getrieberaum Pos. 340.
Grease the parts (35 g); rest into gear compartment pos. 340.
Graisser les pieces (35 g); la graisse restante dans le
compartiment d'engrenage 340.
Engrasar las piezas (35 g); resto en el
compartimento del engranaje pos. 340.

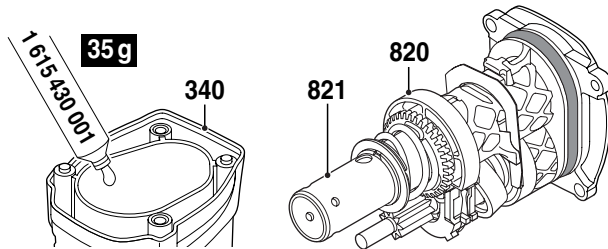
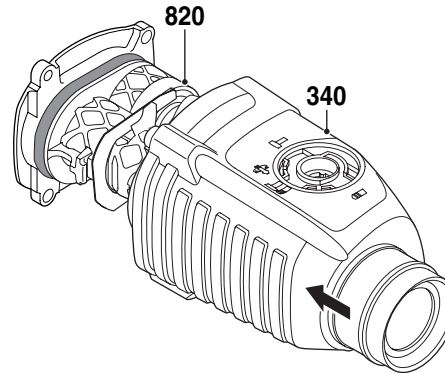
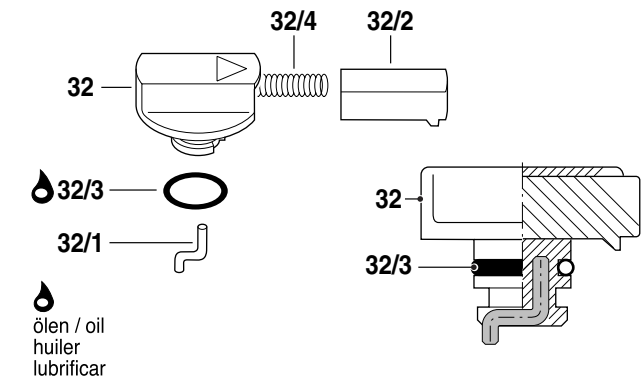
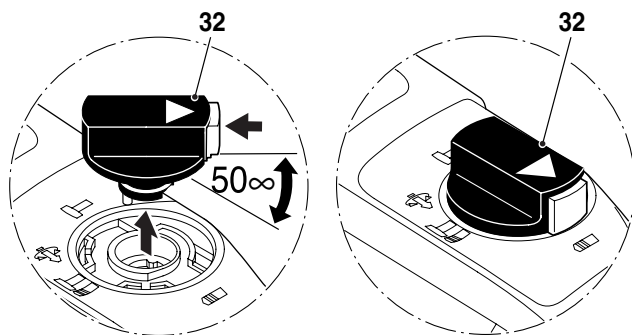
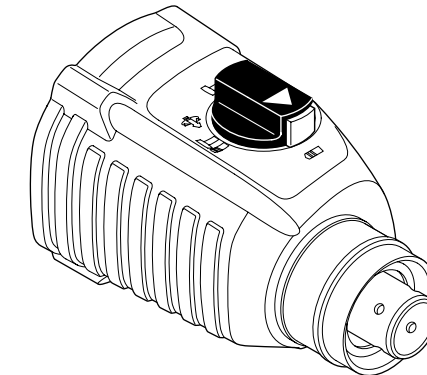
**24.5****25.****25.1****25.2**

26.

* sofern ungefettet
if unlubricated
si n'est pas graisse
si no engrasado

H Ise
Sleeve
Douille
Manguito

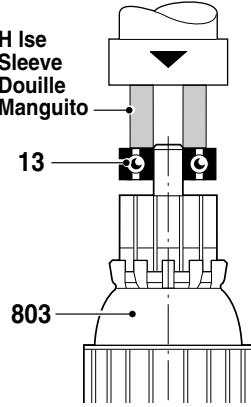
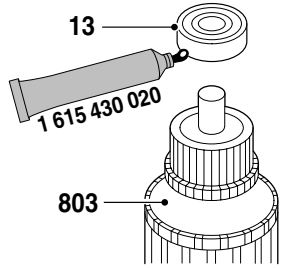

26.1

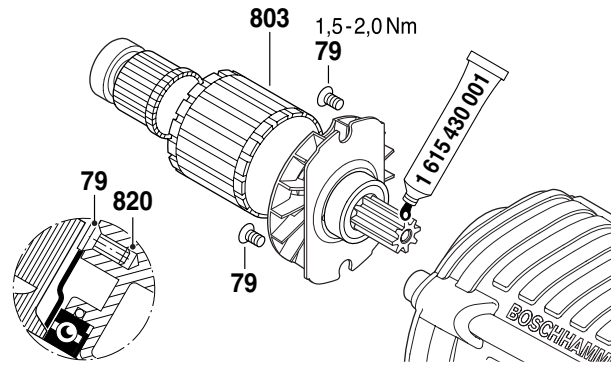

26.2

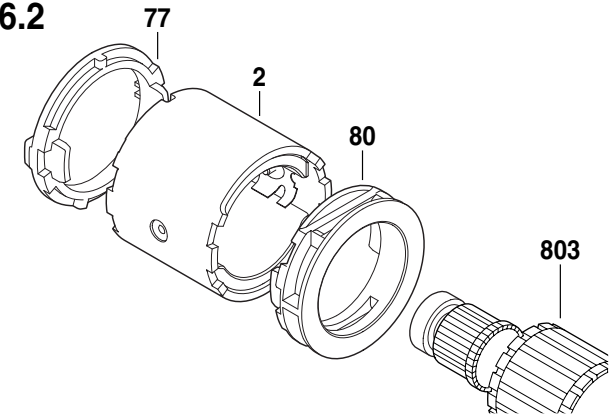

27.

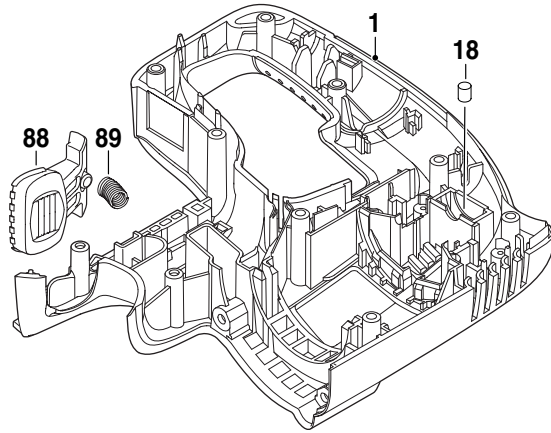

27.2

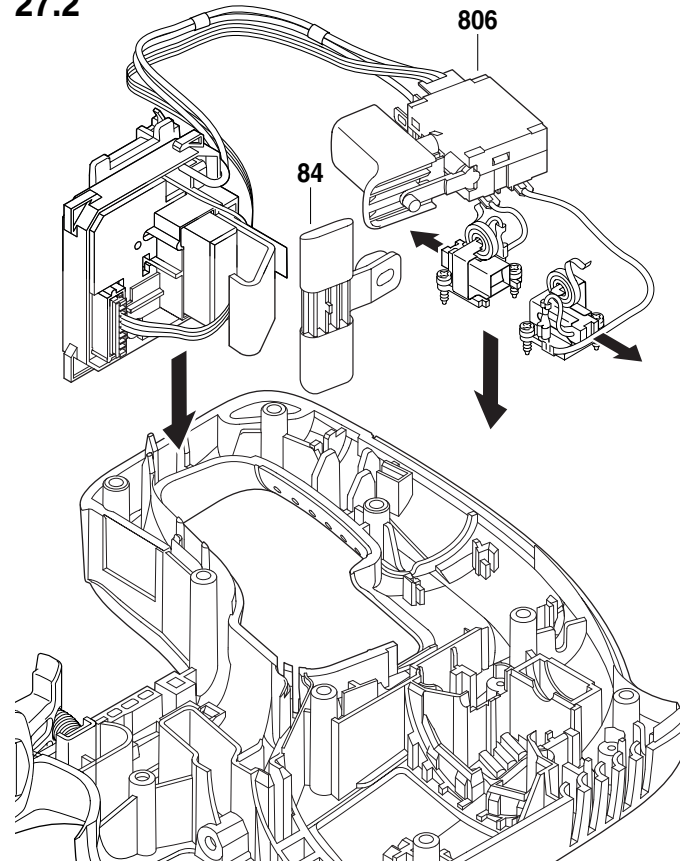

27.1

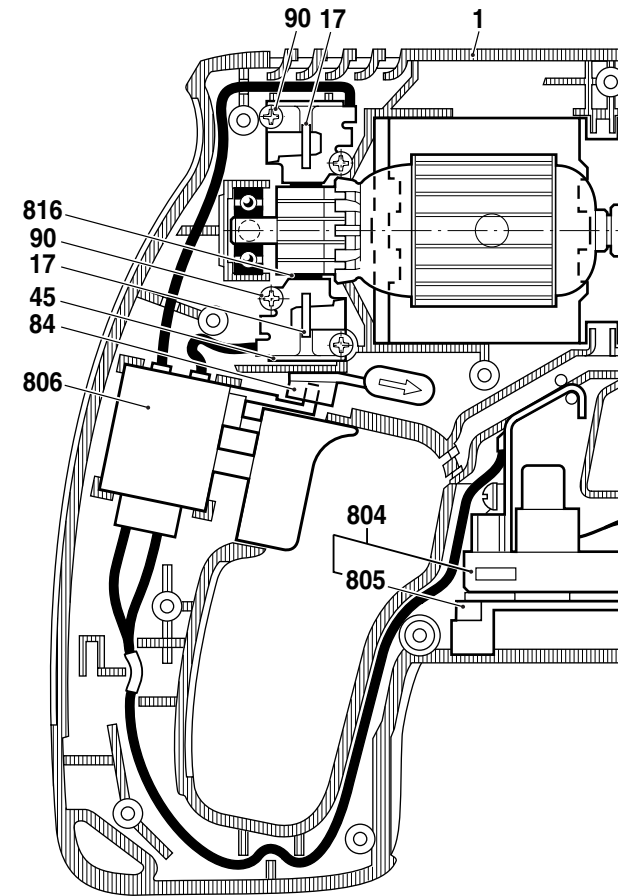
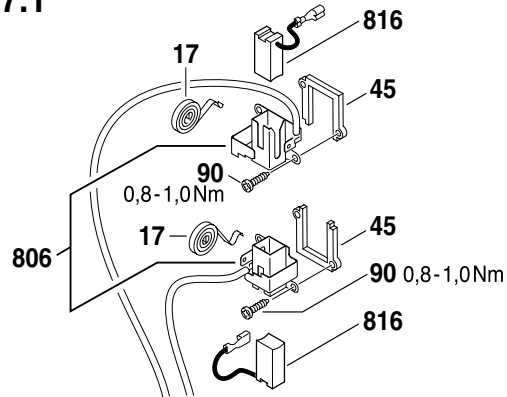

28.

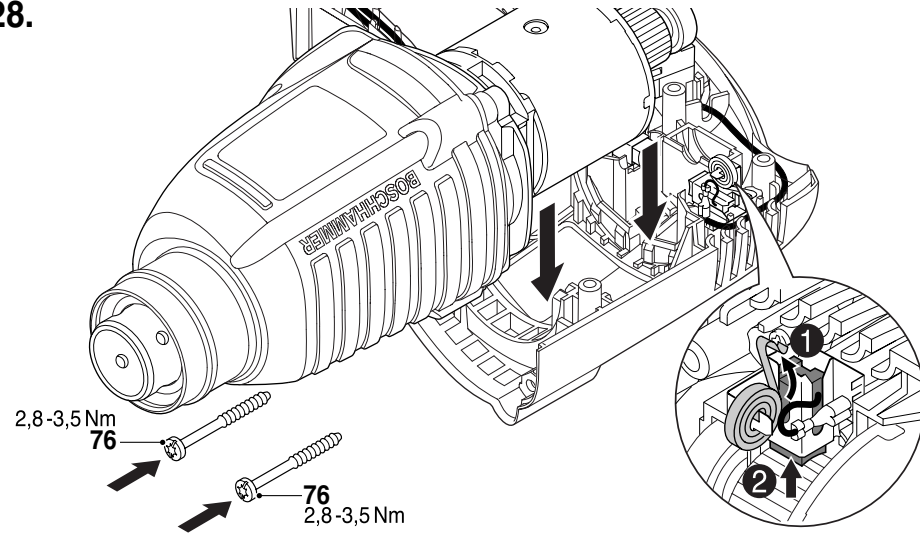

28.1

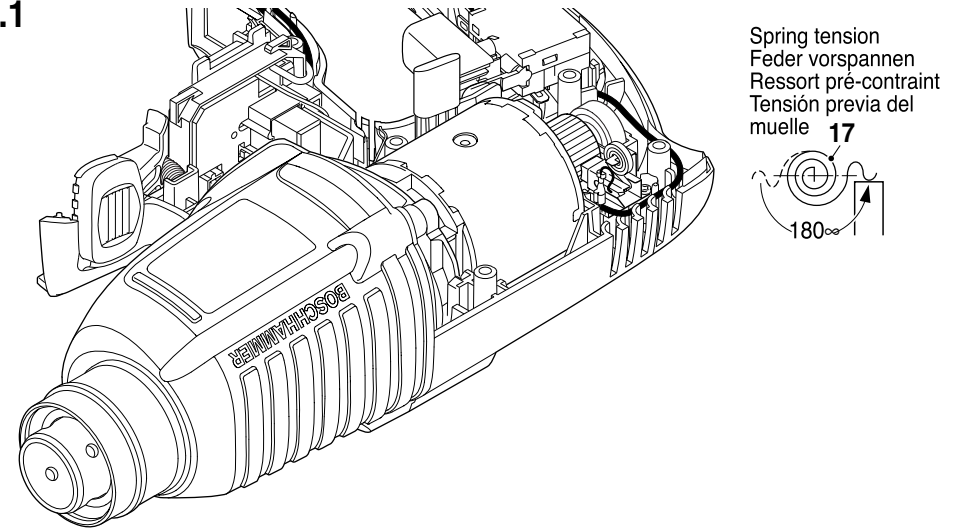

28.2

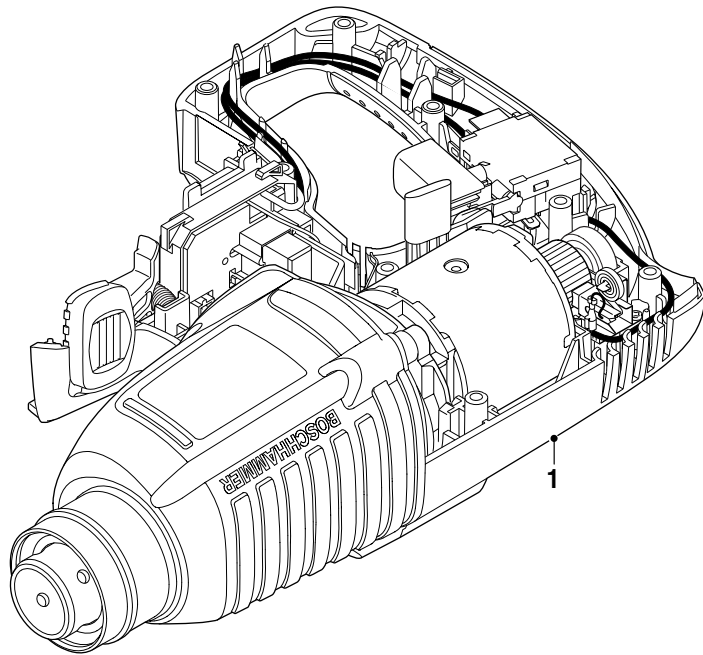

28.3

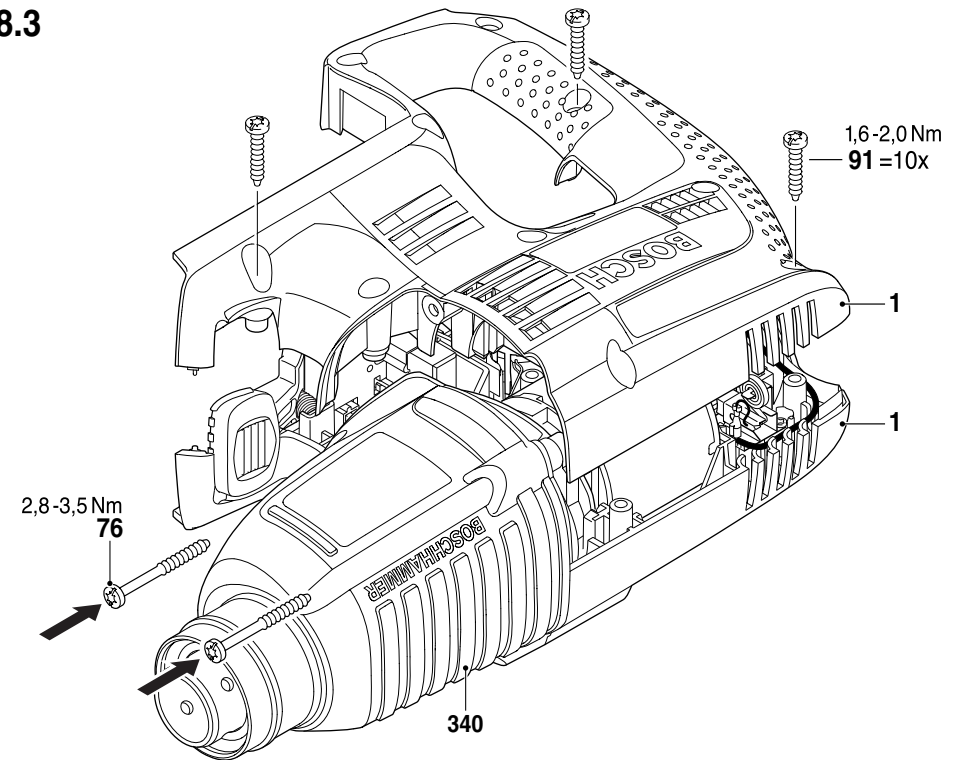

29.

Hohlraum zwischen Dichtlippen füllen
fill cavity between sealing lips
remplir cavite entre les levres du joint
llenar el vacio entre los labios del reten

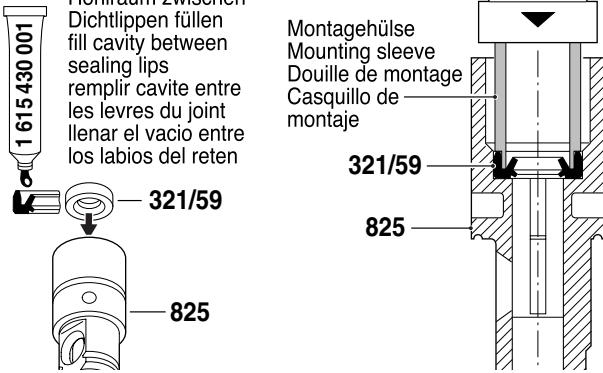

Montagehülse
Mounting sleeve
Douille de montage
Casquillo de montaje

321/59
825

29.1

in Öl tauchen
insert in oil
le plonger dans l'huile
sumergir en aceite

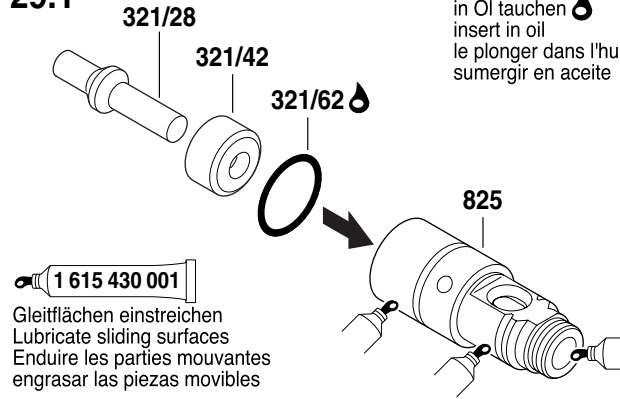

1 615 430 001

Gleitflächen einstreichen
Lubricate sliding surfaces
Enduire les parties mouvantes
engrasar las piezas moviles

321/28
321/42
321/62

825

29.2

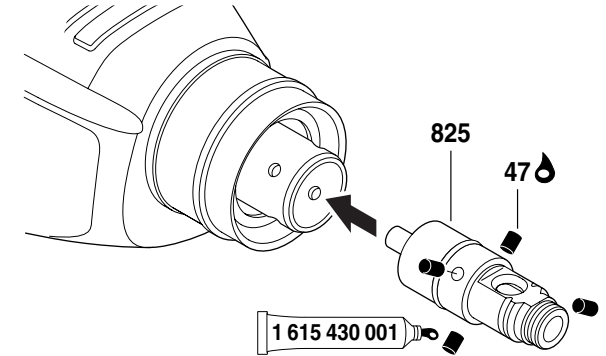

825

47

1 615 430 001

29.3

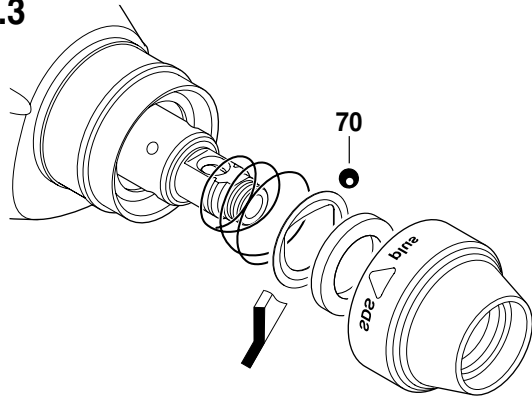

70

29.4

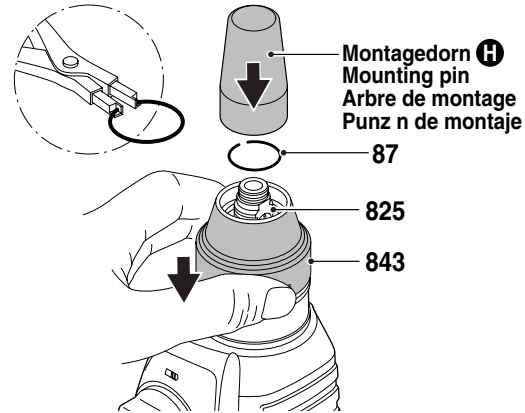

Montagedorn
Mounting pin
Arbre de montage
Punz n de montaje

87

825

843

29.5

Hilfswerkzeug zum Selbst-
anfertigen / Auxiliary tool
(for your own manufacture)
Outil auxiliaire
(fabrication locale)
Utile (fabricaci n particular)

Montagedorn
Mounting pin
Arbre de montage
Punz n de montaje

Maße in mm
Dimensions in mm
Cotes en mm
Medidas en mm

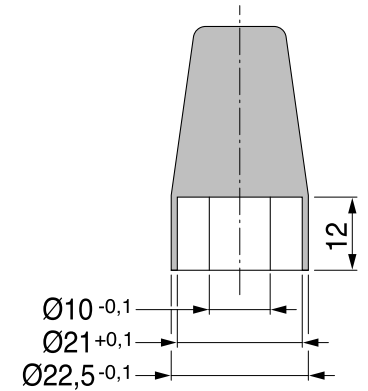

Ø10 -0,1

Ø21 +0,1

Ø22,5 -0,1

12

29.6

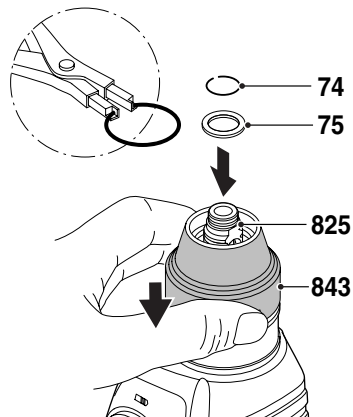

74

75

825

843

29.7

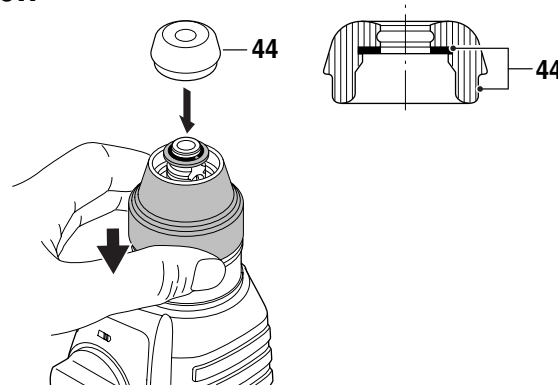

44

44

30.

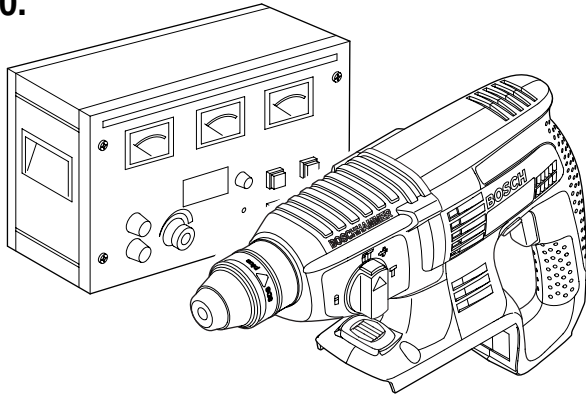

30. Hochspannungsprüfung durchführen.
Beachten:
Die Sicherheitsvorschriften nach DIN, VDE, CEE, AFNOR und weitere in den einzelnen Ländern gültigen Vorschriften sind einzuhalten.
30. Carry out power supply check.
Attention:
Safety regulations according to DIN, VDE, CEE, AFNOR and further regulations applicable in individual countries must be observed.

30. Effectuer un contrôle à haute tension.
Attention:
Respecter les instructions de sécurité selon DIN, VDE, CEE, AFNOR et les autres instructions valables dans les pays respectifs.
30. Efectuar la prueba de alta tensión.
Atención:
Atenerse a las prescripciones de seguridad según DIN, VDE, CEE, AFNOR y a las prescripciones adicionales específicas que pudieran existir en los respectivos países.

31.

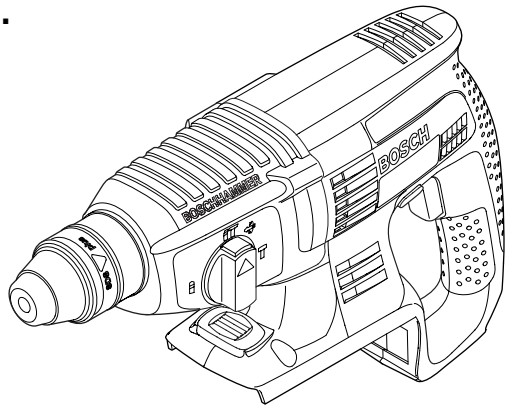

31. Probelauf, Schlagtest, elektrische und mechanische Prüfung durchführen.
31. Perform test run, impact test, electrical and mechanical check-up.

31. Marche à titre d'essai, contrôle de frappe et depercage, effectuer un contrôle mécanique et électrique.
31. Realizar un control funcional, una prueba de taladrado con y sin percusión y los ensayos eléctricos y mecánicos correspondientes.